

# CASCADE PUMP COMPANY

*...manufacturing mixed flow & axial flow pumps since 1948*



## ● INTRODUCTION

---

Cascade Pump is recognized worldwide as a leading source for customer specified, engineered, high capacity axial and mixed flow pumping equipment. Since 1948, our proven design and quality have given thousands of customers the dependability they require in extremely critical applications. Our industry experience and state of the art engineering department offer consulting engineering firms and customers from around the world, valuable design, application and specification support.

At Cascade, we treat every pump project as a custom product, engineered to meet the specific requirements of each individual application. We do this to ensure complete customer satisfaction.



## ● COMPANY BACKGROUND

---

Cascade Pump is a third-generation, family owned and operated business that understands the importance of quality. We are ISO 9001:2015 certified and have been a member of the Hydraulic Institute since 1964. Together, with our valued employees, we take pride in manufacturing an American-made product that continues to meet our customers' expectations of quality, timely delivery and value.



Our manufacturing and sales campus is located 10 miles southeast of Los Angeles, California. The plant is on a ten-acre site with a manufacturing area of approximately 120,000 square feet. Our state of the art machines and manufacturing processes give us the ability to manufacture, test and assemble 100% of our pumps at our factory.

### **TESTING LABORATORY**

Cascade's high capacity test facility is specifically designed for performance testing of vertical wet pit axial and mixed flow pumps. We have the ability to test prototype and model pumps with simulated field sump conditions and submergences. Tests are conducted in accordance with the Hydraulic Institute Test Standards and customer requirements.



## ● AXIAL AND MIXED FLOW STANDARD PUMP DESIGN

**DRIVER:** Pumps are normally driven by vertical electric motors or through right angle gear drives coupled to horizontal engines or electric motors. Hollow or solid shaft driver configurations with engineered shaft couplings and driver mounting designs ensure proper installation and alignment in the field. Hydraulic and mechanical thrust created by the pump is normally carried by a thrust bearing in the driver.

**DISCHARGE:** The pump mounting baseplate is located either above or below the pump discharge nozzle. The elbow guides the flow from vertical to horizontal and can be provided as standard three segment, high efficiency multi-segment long radius, or right angle vaned configurations. The discharge nozzle can be furnished with a customer specified flange or plain end suitable for a mechanical pipe coupling.

**LINESHAFT ASSEMBLY:** Depending on lubrication type, the lineshaft is made from PSQ (pump shaft quality) C-1045 carbon steel for oil and grease lubrication or Type 416 stainless steel for product or positive water flush lubrication. Shaft coupling standard material is carbon steel. Other material options are available where additional strength or corrosion protection is desired. Shaft enclosing tubes are made from extra heavy schedule 80 pipe. Lineshaft bearings are made from bronze with external threads to act as couplings for enclosing tubes. Normal bearing spacing is 60" but may vary depending on shaft diameter and rotating speed. Open lineshaft product lubricated designs have either bronze or fluted rubber bearings.

**COLUMN ASSEMBLY:** Discharge elbow and flanged column sections are fabricated from carbon steel pipe and plate. Column flanges are machined on centers with rabbet fit registers to ensure positive alignment when connected to mating parts.

**BOWL ASSEMBLY:** Standard construction suction and discharge bowls are Class 30 cast iron. The impeller/propeller is cast bronze held to the bowl shaft with split thrust collars and key made from stainless steel. The suction bowl incorporates a flared inlet with straightening vanes. The discharge bowl has diffusion vanes that convert the velocity of the water leaving the impeller/propeller into pressure head. Bronze sleeve type shaft guide bushings are provided above and below the impeller. The standard bowl shaft material is 416 stainless steel PSQ.

### OPTIONAL FEATURES:

- Special coatings suitable for corrosion or erosion applications
- Spray-on or replaceable shaft sleeves
- Long radius or right angle veined discharge elbow
- Special material for bowl and impeller/propeller castings
- Special material for fabrication of discharge column and elbow
- Separate soleplate for ease of installation and maintenance
- Special shaft materials for corrosion or erosion capability
- Replaceable bowl liner
- Suction strainer, umbrella and or vortex suppressor
- FSI (formed suction inlet)
- Special lubrication systems including water flush and automatic grease



# PERFORMANCE CHARTS

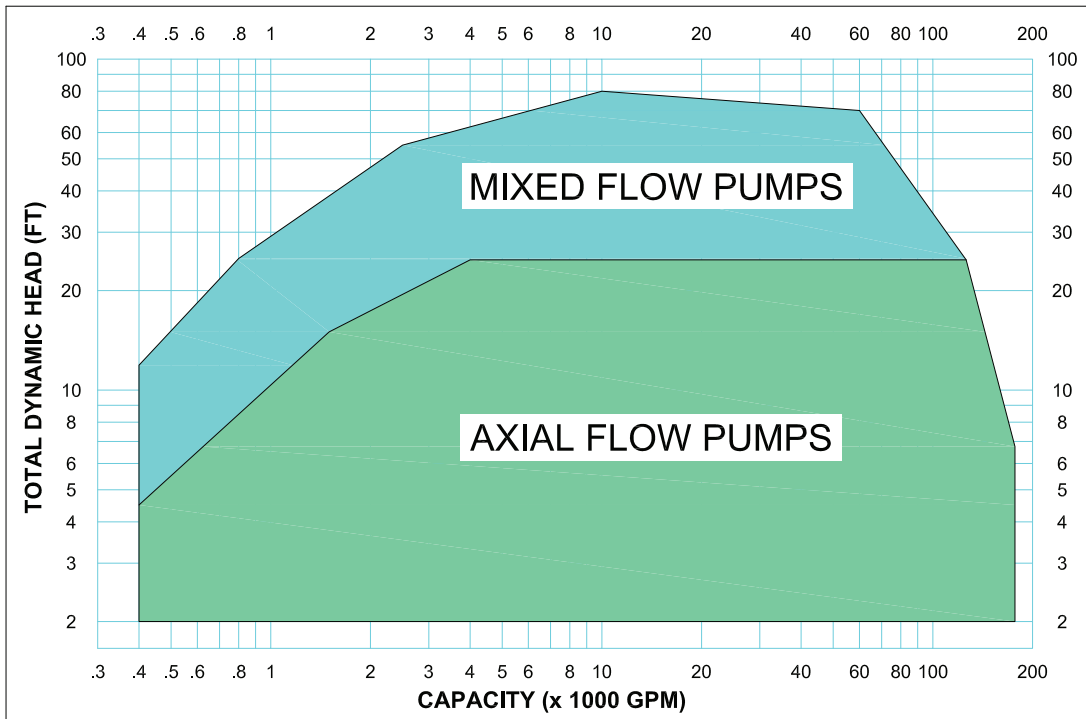

Performance chart is based on single stage only. Other pump designs are available which include multiple stages and may cover ranges not shown.

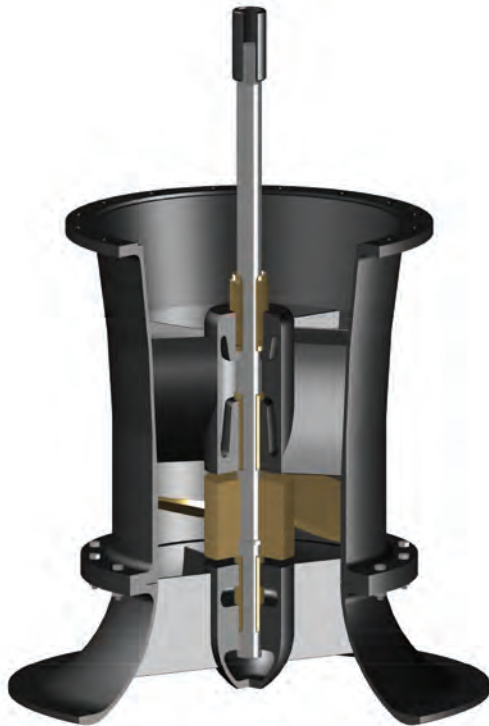

## AXIAL FLOW

Head: 5 thru 26 feet per stage  
Capacity: 200 thru 200,000 GPM



## MIXED FLOW

Heads: 10 thru 130 feet  
Capacity: 500 thru 120,000 GPM

## ● MUNICIPAL APPLICATIONS

---

Flood Control, Storm Water, Water Transfer, Water and Waste Water Treatment including: Return Activated Sludge (RAS), Mixed Liquor, Backwash, Filter Influent, Filter Feed, UV Feed, Secondary Effluent, Primary Effluent and Final Effluent.



**95,000 GPM STORM WATER PUMP**



**RETURN ACTIVATED SLUDGE (RAS)**

## ● OTHER APPLICATIONS

---



### **INDUSTRIAL:**

Pulp & Paper, Brine Transfer, Cooling Tower, Process, Mine Dewatering, Desalination Plants, Fish Hatcheries, Circulating Water and Raw Water.



### **RECREATIONAL:**

Wave Development, Artificial River, Theme Parks, and Fountains.



### **AGRICULTURE:**

Flood, Irrigation, Tail Water, Drainage, Fish Farms and Shrimp Farms.

### **MISCELLANEOUS:**

Water Tunnel, Aqua Culture, Hydro Turbines, Golf Courses, Dry Docks, Defense, Bow Thrusters, Bilge, Ballast Tanks, Jet Aerators, Land Reclamation, Airport/Highway Drainage, Food Processing, and Motion Picture Sets.

## ● HORIZONTAL PUMPS

---

Horizontal pumps can be used in various applications that require high capacity low head conditions of service. Our engineering department designs horizontal pumps that are customized to your design criteria, which include configurations such as dry pit, reverse flow, rotated discharge to desired angle, motor on suction side and pulley assembly. There are many features offered on the horizontal pump design, including a thrust pot assembly, bi-directional thrust pot, mechanical seal, hydrostatic testing, mounting base for pump and driver, ANSI suction and discharge connections, flexible pipe coupling connection, and all stainless steel construction. Horizontal axial and mixed flow pumps, require positive suction head to operate correctly.



*Return Activated Sludge (RAS)*



*Circulation Pump at Hydraulics Laboratory*



*Primary Effluent*

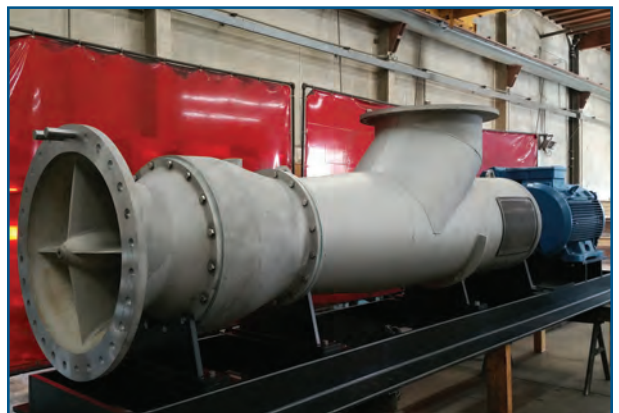

*Industrial Circulation – All 316 Stainless Construction*



## ● OTHER PUMP OPTIONS



*Complete Stainless-Steel Pump and or Components*



*Slant Mount Configuration*



*FSI (Formed Suction Intakes)*



*Horizontal Motor to Gear Drive*



*Mounted on Barges*



*In-Line Booster Can*

# ● LUBRICATION SYSTEMS

---

## OIL LUBRICATION

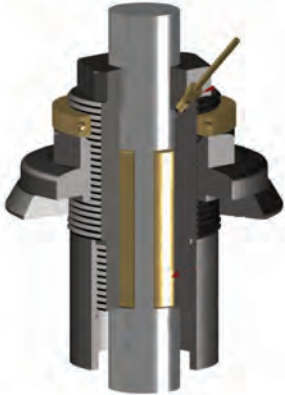

- **APPLICATIONS** – Flood Control, Storm Water, Irrigation, Dewatering Ditch Pumping
- **LIQUID CONDITIONS** – Clear Water, Slight Sand, Slight Silt
- **DESCRIPTION** – Gravity feed to enclosed lineshaft bearings and bowl bushings from oil reservoir with solenoid valve. Grease packed suction bowl bushing.

## PRODUCT LUBRICATION

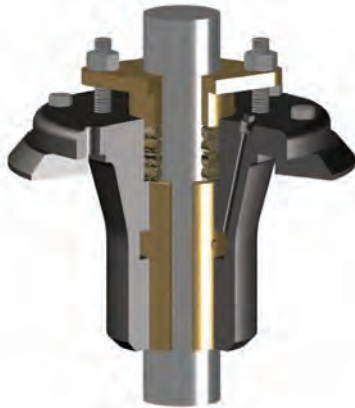

- **APPLICATIONS** – Municipal Water, Circulation, Process, Amusement Parks, Salt Water, Dry Docks, Canal Diversion, Fish Hatcheries, Chemicals, Booster Pumping
- **LIQUID CONDITIONS** – Clear Water, Potable Water, Corrosive, Chemicals
- **DESCRIPTION** – Open stainless steel lineshaft with fluted rubber lineshaft bearings. Grease lubricated packing box with gland.

## WATER FLUSH AND GREASE LUBRICATED

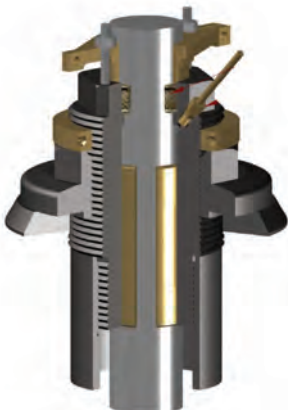

- **APPLICATIONS** – Sewage Treatment, Paper Pulp, Raw Water, Effluent, Storm Water, Mixed Liquor, Combined Sewer Overflow, Flood Control, Amusement Parks, Booster Pumping, Drainage
- **LIQUID CONDITIONS** – Severe Sand, Severe Silt, Severe Abrasive, Clear Water
- **DESCRIPTION FOR WATER FLUSH** – Positive clean water flush to all bearings. Enclosed stainless steel lineshaft. Separate flushline to suction bowl bushing. Packing box with gland.
- **DESCRIPTION FOR GREASE** – Factory grease packed enclosed lineshaft and suction bowl bushing. Gland or seal at stuffing box. This design can be upgraded to include grease lines to all bearing points with a manual or fully automatic grease pump.

# ENGINEERING ANALYSIS

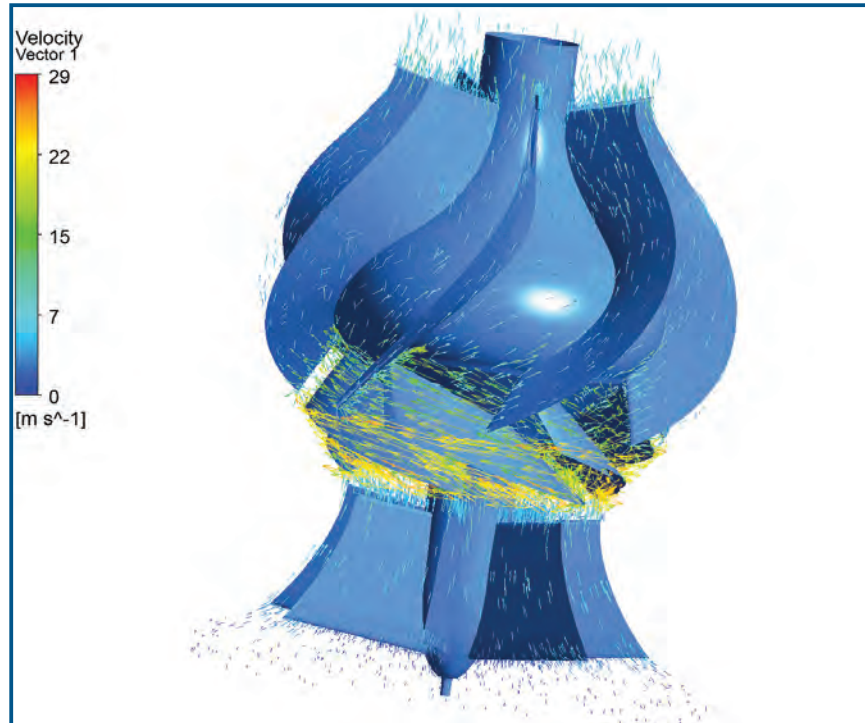

Cascade is continuously researching and developing new pump models capable of larger capacities, higher design pressures and greater efficiency to meet our customers' ever evolving requirements. We are able to use CFD (Computational Fluid Dynamics) to predict pump performance for new models and application specific requirements.

Cascade has internal staff engineers that can perform an FEA (Finite Element Analysis) for VFD applications and vibration specifications. This analysis can predict at what RPM mode shape vibrations could occur in the field.





Please note: The information contained herein is general in nature and is not intended for specific application, construction, or installation purposes. Cascade Pump Company reserves the right to make changes in the information shown herein, add improvements, or discontinue manufacture at any time without notice or obligation.

Compliance with Federal, State, Municipal and Local regulations and laws concerning the environment, pollution, occupational health and safety may be affected by the installation, operation and use of this equipment and other matters over which Cascade Pump Company has no control. Cascade Pump Company assumes no responsibility for compliance with these laws or regulations whether by way of indemnity, warranty or otherwise.



**CASCADE PUMP COMPANY**  
MANUFACTURERS OF MIXED FLOW & AXIAL FLOW PUMPS

10107 South Norwalk Boulevard | PO Box 2767  
Santa Fe Springs, CA 90670-0767  
Tel: 562.946.1414 | Fax: 562.941.3730  
[www.cascadepump.com](http://www.cascadepump.com)  
email: [pumpinfo@cascadepump.com](mailto:pumpinfo@cascadepump.com)

